

This version may be out of date. Please check for latest version at : www.garethfry.co.uk and click on Specifications link.
Please refer to <http://www.garethfry.co.uk/Specs/visualdictionary.pdf> for explanations of UK theatre terms

VENUE to provide:

Left-Centre-Right vocal clusters, consisting of point source speakers or line-arrays as appropriate to the auditorium. Please contact us to discuss the possibilities for your auditorium

Front Fills: 3 x / 6 x Meyer UPM's or equivalent, depending on width of stage

2 x d&b Qsubs or Meyer USW sub-bass speakers.

3 x delay speakers, or more depending on the auditorium size and type.

Exact speaker quantities and types will need to be determined for each venue. We are open to suggestions for substitutions, but these must be approved by Gareth Fry or Fergus Mount at least 2 weeks in advance of the fit-up.

2 x Sennheiser MKH416 microphones

8 x Shure UHF radio mic system with UR1M transmitters and receivers; OR Sennheiser 5012, 5212, 6212 transmitters and compatible receivers.

With 4 x spare transmitter aerials.. Shure UR1 transmitters and SK50 transmitters are too big and are **NOT** acceptable. Due to the physical nature of the show, if UR1M/SK5012/SK5212/SK6212 transmitters are not provided, DV8 will need to air-freight these from the UK at the cost of the venue. Batteries should be supplied to allow for a battery change for every performance and every 5 hours of technical rehearsals.

In countries using 110V, we will need 3 x Yamaha P5000 amplifiers, or equivalent, as our touring amplifiers will not work on 110V.

Please note: We are not touring radio mic runners and will need ONE (1) person in each venue to be responsible for preparing the mic capsules, changing batteries before each performance and monitoring & sorting any problems out during the show. * The same person must be available for all tech sessions, rehearsals and performances. * That person should have a good supply of Transpore, Tegaderm, Micropore, Zinc Oxide and Hapla band, as well as flesh coloured vinyl paints, hair and makeup products to conceal the microphones. We will provide them with a list of responsibilities but we will assume that they are already experienced with radio mics.

Cable: Speaker cable, XLR, mains cable, etc should be provided by the venue to connect the system as detailed in the attached schematic & layout plans.

Mains: The system should be connected to a dedicated sound mains supply, i.e. not used for anything other than sound equipment. Mains distribution should be provided as necessary. For countries using 110V mains systems we will require a 110V-240V transformer at FOH. An APC-1400 Smart UPS, or equivalent (for computers and DME at mix position) should be provided in case of power loss or surge.

Please note: all equipment supplied must be of professional audio quality, in good working order and constant for the duration of the run. We reserve the right to reject any item supplied, if it is deemed to be of inadequate quality, unsuitable for its supposed purpose or in poor condition whether of a cosmetic or electrical nature. All speakers, rigging accessories, mic. stands etc must be matt black in colour.

DV8 to provide:

Yamaha M7CL-48 mixer

Yamaha DME24 with Focusrite RedNet3 and Creamware A16, providing analogue outputs on 24x XLR3M outputs

DPA4061 mic capsules with connectors for Shure UR1M (TA4M) or Sennheiser SK5212/SK6212 (3pin mini Lemo)transmitters

2 x Apple Mac's running QLab with sound-cards

5 x DPA 2011 float mics

2 x EM Acoustics EMS8x1's Upstage, flown horn down Upstage at side of aperture

1 x EM Acoustics EMS81x, flown horn down CS C

3(4) x EM Acoustics EMS51s, for front foldback

6 x the box Pro achat speakers for foldback

3 x Yamaha P7000/5000/2500 amplifiers. Please note we we will not tour these amplifiers to venues outside Europe as they are 240V compatible only.



| Yamaha M7CL-48 | | | | 2X MY-AUD DANTE CARDS | | | |
|----------------|---------|----------------|-----------------------------|-----------------------|-----------|--|--|
| SLOT 1-1/2-1 | 33 | QLAB 1 US L | MIX 1 | US L | SLOT 1-1 | | |
| SLOT 1-2/2-2 | 34 | QLAB 2 US R | MIX 2 | US R | SLOT 1-2 | | |
| SLOT 1-3/2--3 | 35 | QLAB 3 PCM L | MIX 5 | SUB L | SLOT 1-3 | | |
| SLOT 1-4/2-4 | 36 | QLAB 4 PCM R | MIX 6 | SUB R | SLOT 1-4 | | |
| SLOT 1-5/2-5 | 37 | QLAB 5 SUB L | MIX 7 | FB DS L | SLOT 1-5 | | |
| SLOT 1-6/2-6 | 38 | QLAB 6 SUB R | MIX 8 | FB DS R | SLOT 1-6 | | |
| SLOT 1-7/2-7 | 39 | QLAB 7 FB DS L | MIX 9 | FOH L | SLOT 1-7 | | |
| SLOT 1-8/2-8 | 40 | QLAB 8 FB DS R | MIX 10 | FOH R | SLOT 1-8 | | |
| | | | | | | | |
| SLOT 1-9/2-9 | 41 | QLAB 9 FOH L | MIX 11 | | SLOT 1-9 | | |
| SLOT 1-10/2-10 | 42 | QLAB 10 FOH R | MIX 12 | CS C | SLOT 1-10 | | |
| SLOT 1-11/2-11 | 43 | QLAB 11 CS L | MIX 13 | | SLOT 1-11 | | |
| SLOT 1-12/2-12 | 44 | QLAB 12 CS C | MIX 14 | TV | OMNI 3 | | |
| SLOT 1-13/2-13 | 45 | QLAB 13 CS R | MIX 15 | | SLOT 1-12 | | |
| SLOT 1-14/2-14 | 46 | QLAB 14 TV | MIX 16 | | SLOT 1-13 | | |
| SLOT 1-15/2-15 | 47 | QLAB 15 F FB | STEREO L | VOX L | SLOT 1-14 | | |
| SLOT 1-16/2-16 | 48 | | MONO | VOX C | SLOT 1-15 | | |
| | | | STEREO R | VOX R | SLOT 1-16 | | |
| | | | | | | | |
| | 17 | FLOAT L | | | | | |
| | 18 | FLOAT CL | | | | | |
| | 19 | FLOAT C | | | | | |
| | 20 | FLOAT CR | | | | | |
| | 21 | FLOAT R | | | | | |
| | 22 | RIFLE L | | | | | |
| | 23 | | | | | | |
| | 24 | RIFLE R | | | | | |
| | | | | | | | |
| | 25 | Hannes | | | | | |
| | 26 | Vivien | | | | | |
| | 27 | Emira | | | | | |
| | 28 | Andy | | | | | |
| | 29 | Ian G | | | | | |
| | 30 | Taylor | | | | | |
| | 31 | Gabriel | | | | | |
| | 32 | Garth J | | | | | |
| | | | | | | | |
| | | | MATRIX 1 | | | | |
| | | | MATRIX 2 | | | | |
| | | | MATRIX 3 | | | | |
| | | | MATRIX 4 | | | | |
| | | | MATRIX 5 | | | | |
| | | | MATRIX 6 | | | | |
| | | | MATRIX 7 | | | | |
| | | | MATRIX 8 | | | | |
| | | | | | | | |
| | ST1L | LAPTOP L | | | | | |
| | ST1R | LAPTOP R | | | | | |
| | ST2L | LAPTOP L | | | | | |
| | ST2R | LAPTOP R | | | | | |
| | ST3L | | | | | | |
| | ST3R | | | | | | |
| | | | | | | | |
| | | | MIX 3 | PCM L | OMNI 1 | | |
| | | | MIX 4 | PCM R | OMNI 2 | | |
| | | | | | | | |
| | ST4L | ST4L | LEXICON | | | | |
| | ST4R | ST4R | LEXICON | | | | |
| | NETWORK | | | | | | |
| | | | SECONDARY PORT DANTE CARD A | | | | |
| | | | SECONDARY PORT DANTE CARD B | | | | |
| | | | WC MASTER | | | | |
| | | | MIDI IN | | | | |

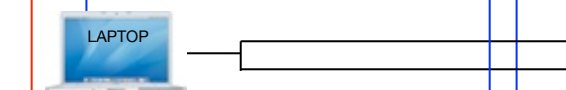
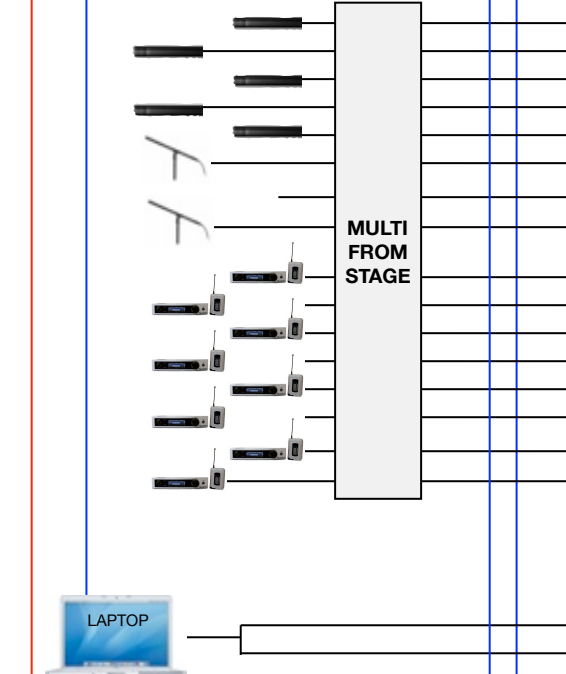
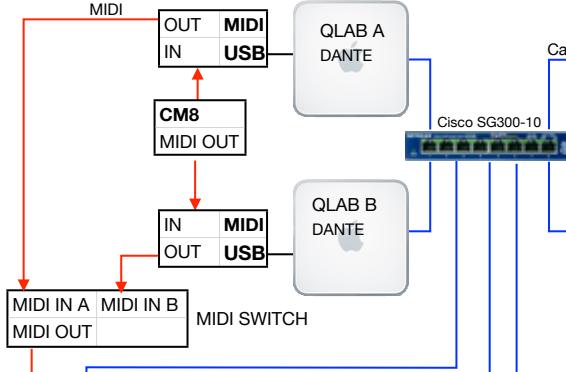

| Yamaha DME24 1 x MY-AUD DANTE CARD | | | | | |
|------------------------------------|----|---------|------------------|----|-----------|
| SLOT 1-1 | 1 | US L | US L | 1 | SLOT 1-1 |
| SLOT 1-2 | 2 | US R | US R | 2 | SLOT 1-2 |
| SLOT 1-3 | 3 | SUB L | SUB L | 3 | SLOT 1-3 |
| SLOT 1-4 | 4 | SUB R | SUB R | 4 | SLOT 1-4 |
| SLOT 1-5 | 5 | FB DS L | FB FRONT | 5 | SLOT 1-5 |
| SLOT 1-6 | 6 | FB DS R | FB US | 6 | SLOT 1-6 |
| SLOT 1-7 | 7 | FOH L | FOH L STALLS | 7 | SLOT 1-7 |
| SLOT 1-8 | 8 | FOH R | FOH R STALLS | 8 | SLOT 1-8 |
| | | | | | |
| SLOT 1-9 | 9 | CS 81 | FOH L CIRCLE | 9 | SLOT 1-9 |
| SLOT 1-10 | 10 | TV | FOH R CIRCLE | 10 | SLOT 1-10 |
| SLOT 1-11 | 11 | FLOAT L | FOH L UPPER CIRC | 11 | SLOT 1-11 |
| SLOT 1-12 | 12 | FLOAT C | CS C | 12 | SLOT 1-12 |
| SLOT 1-13 | 13 | FLOAT R | TV | 13 | SLOT 1-13 |
| SLOT 1-14 | 14 | VOX L | | 14 | SLOT 1-14 |
| SLOT 1-15 | 15 | VOX C | | 15 | SLOT 1-15 |
| SLOT 1-16 | 16 | VOX R | VOX L | 16 | SLOT 1-16 |
| | | | VOX C | 17 | analog 1 |
| | | | VOX R | 18 | analog 2 |
| WC IN | | | FRONT FILLS L | 19 | analog 3 |
| MIDI IN | | | FRONT FILLS C | 20 | analog 4 |
| | | | FRONT FILLS R | 21 | analog 5 |
| | | | DELAY 1 | 22 | analog 6 |
| | | | DELAY 2 | 23 | analog 7 |
| | | | | 24 | analog 8 |
| NETWORK | | | WC OUT | | |
| MIDI THRU | | | MIDI IN | | |

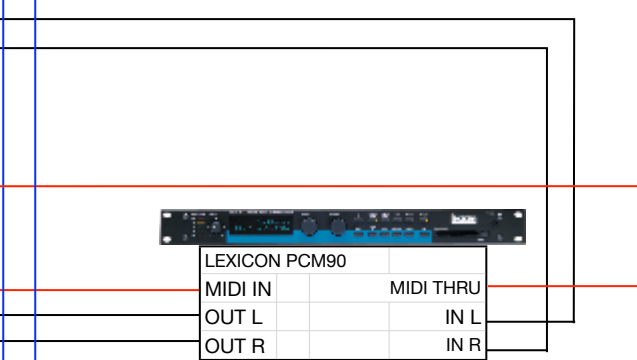

Cisco SG300-10

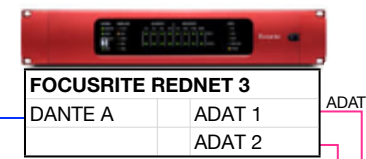

| CREAMWARE A16 | |
|---------------|------------------|
| ADAT 1-1 | US L |
| ADAT 1-2 | US R |
| ADAT 1-3 | SUB L |
| ADAT 1-4 | SUB R |
| ADAT 1-5 | FB DS L |
| ADAT 1-6 | FB DS R |
| ADAT 1-7 | FOH L STALLS |
| ADAT 1-8 | FOH R STALLS |
| ADAT 1-9 | FOH L CIRCLE |
| ADAT 1-10 | FOH R CIRCLE |
| ADAT 1-11 | FOH L UPPER CIRC |
| ADAT 1-12 | FOH R UPPER CIRC |
| ADAT 1-13 | CS C |
| ADAT 1-14 | TV |
| ADAT 1-15 | |
| ADAT 1-16 | |

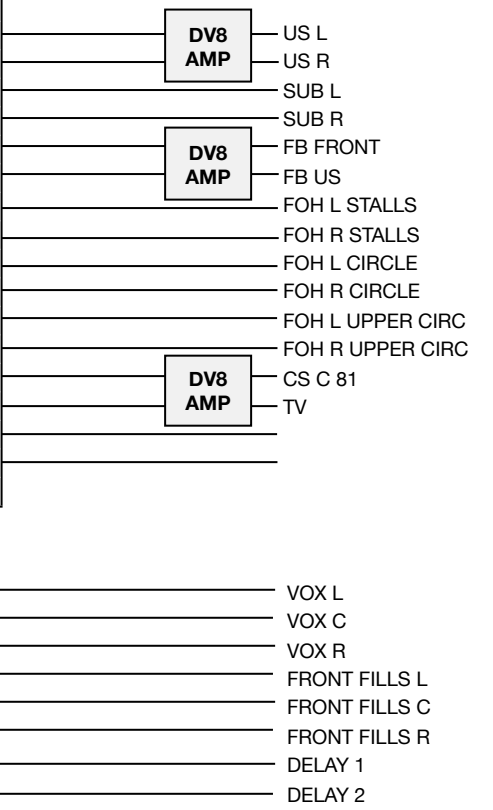

Notes:
 - Not to scale
 - This drawing & the specifications therein, relate only to aural and visual aspects of the production, and not to matters of structural integrity and/or safety.

**PLEASE NOTE: WE REQUIRE AN AUDITORIUM MIX POSITION: THIS MUST BE A LEVEL AREA OF 2.8m x 1.8m.
 ALL VENUES ARE REQUESTED TO CONFIRM WITH THEIR BOX OFFICE TO ENSURE THAT, IF NECESSARY, THE REQUIRED SEATING HAS BEEN TAKEN OFF SALE.**

